

Molded Case Circuit Breaker Product Family

2



Contents

<i>Description</i>	<i>Page</i>
Standards and Certifications	V4-T2-255
Quick Reference	V4-T2-256
G-Frame (15–100 Amperes)	V4-T2-259
F-Frame (10–225 Amperes)	V4-T2-273
J-Frame (70–250 Amperes)	V4-T2-291
K-Frame (70–400 Amperes)	V4-T2-299
L-Frame (125–600 Amperes)	V4-T2-323
M-Frame (300–800 Amperes)	V4-T2-349
N-Frame (400–1200 Amperes)	V4-T2-360
R-Frame (800–2500 Amperes)	V4-T2-375
Motor Circuit Protectors (MCP)	V4-T2-394
Motor Protection Circuit Breakers (MPCB)	V4-T2-405
Type ELC Current Limiter Attachment (Size 0–4)	V4-T2-407
Current Limiting Circuit Breaker Module	V4-T2-408
Internal Accessories	V4-T2-411
External Accessories	V4-T2-444



Product Overview

Eaton’s molded case circuit breakers are designed to provide circuit protection for low voltage distribution systems. They are described by NEMA as, “... a device for closing and interrupting a circuit between separable contacts under both normal and abnormal conditions,” and furthermore as, “... a breaker assembled as an integral unit in a supporting and enclosing housing of insulating material.” The National Electrical Code (NEC) describes them as, “A device designed to open and close a circuit by non-automatic means, and to open the circuit automatically on a predetermined overload of current, without injury to itself when properly applied within its rating.”

So designed, Eaton circuit breakers protect conductors against overloads and conductors and connected apparatus, such as motors and motor starters, against short circuits.

In low voltage distribution systems, there are many varied applications of molded case circuit breakers.

Eaton offers the most comprehensive family of molded case circuit breakers in the industry.

This section of circuit breakers includes:

- Thermal-magnetic trip breakers
- Electronic rms trip breakers
- Molded case switches
- Motor circuit protectors
- Current limiting breakers
- Special application breakers

Modified Breakers

Eaton breakers can be ordered with internal accessories installed. These modified breakers will be subject to an addition charge.

Special Calibration

Special non-UL-listed calibrations are available for certain ambient temperatures other than 40 °C and for frequencies other than 50/60 Hz or DC. Reduced interrupting ratings will apply for 400 Hz applications.

50 °C Calibration

Add suffix **V** to catalog Number for complete breaker, listed above, when ordering listed ampere ratings for breakers to be used in 50 °C ambients. (No UL label.)

Moisture-Fungus Treatment

All circuit breaker cases are molded from glass-polyester which does not support the growth of fungus. Any parts which are susceptible to the growth of fungus will require special treatment.

Freeze-Tested Circuit Breakers

The circuit breakers may be ordered with freeze testing. This option uses special lubrication and mechanical operation is verified at –40 °C.

Marine Applications

E- to R-Framed circuit breakers can be supplied to meet the following marine specifications:

- U.S. Coast Guard CFR 46; ABS—American Bureau of Shipping; IEEA 45; DNV; Lloyds; and ABS/NVR

These specifications generally require molded case circuit breakers to be supplied with 50 °C ambient, and plug-in adapter kits. When plug-in adapter kits are used, no terminals need be supplied (switchboard applications).

Circuit breakers can also be supplied to meet UL 489 Supplement SA (Marine use) and UL 489 Supplement SB (Naval Use).

UL 489 Supplement SA applies to vessels over 65 feet (19.8 m) in length. Requirements include 40 °C ambient calibration, special labeling, and no use of aluminum conductors or terminals. (No 50 °C.)

- Suffix H08

Or you can choose to add 50 °C ambient but then there is no “UL” mark.

- Suffix VH08

UL 489 Supplement SB requires partial 50 °C ambient calibration, vibration testing, special nameplating and no use of aluminum conductors or terminals. Eaton chooses to always fully calibrate to 50 °C ambient. (“Naval” labeled per UL, and UL now allows 50 °C label here.)

- Suffix VH09

Certified Test Reports

Eaton breakers can be ordered with certified test reports at the time of order entry. Test report documents the thermal and magnetic or electronic tripping characteristics of the individual breaker. Breaker and test report must be ordered together. Add suffix 12 to breaker catalog number and enter separate line item on order for certified test report.

Standards and Certifications

Molded case circuit breakers are designed to conform with the following standards:

- Underwriters Laboratories Inc., Standard UL 489, molded case circuit breakers and circuit breaker enclosures
- National Electrical Manufacturers Association (NEMA) Standards Publication No. AB1-1993, molded case circuit breakers
- Australian Standard AS 2184, molded case circuit breakers
- British Standards Institution Standard BS 4752: Part 1, switchgear and control gear Part 1: circuit breakers
- Canadian Standards Association (CSA) Standard C22.2 No. 5, service entrance and branch circuit breakers
- International Electrotechnical Commission Recommendations IEC 60947-2, circuit breakers
- Japanese T-Mark Standard molded case circuit breakers
- South African Bureau of Standards, Standard SABS 156, Standard Specification for molded case circuit breakers
- Swiss Electro-Technical Association Standard SEV 157-1, safety regulations for circuit breakers
- Union Technique de l'Electricite Standard NF C 63-120, low voltage switchgear and control gear circuit breaker requirements
- Verband Deutscher Elektrotechniker (Association of German Electrical Engineers) Standard VDE 0660, low voltage switchgear and control gear, circuit breakers

Conformance with these standards satisfies most local and international codes, assuming user acceptability and simplified application.

Molded case circuit breakers equal or exceed Federal Specification Classification W-C-375b requirements for the particular class associated with the circuit breaker frame being considered.

Open breakers do not have service entrance ratings. Service entrance rating is part of the enclosure.



Quick Reference

Industrial Circuit Breakers

2

G-Frame

Circuit Breaker Type	Continuous Ampere Rating at 40 °C	No. of Poles	Volts		Type of Trip ^①	Federal Specification W-C-375b	UL Listed Interrupting Ratings (rms Symmetrical Amperes)							Page Number	
			AC	DC			AC (kA)				DC (kA) ^②				
							120	120/240	240	277	480	600	125 ^③	250	
GHB	15–100	1	120	125	N.I.T.U.	11a	65	—	—	—	—	—	14	—	V4-T2-264
GHB	15–100	2, 3	240	125/250	N.I.T.U.	11a10b, 11b	—	—	65	—	—	—	—	14	V4-T2-264
GHB	15–100	1	277	125	N.I.T.U.	12b, 14b	—	—	—	14	—	—	14	—	V4-T2-264
GHB	15–100	2, 3	480Y/277	125/250	N.I.T.U.	15b	—	—	—	14	14	—	—	14	V4-T2-264
HGHB	15–30	1	277	125	N.I.T.U.	12c, 13a, 13b	65	—	—	25	—	—	14	—	V4-T2-264
GHBS	15–30	1, 2	480Y/277	—	—	—	65	65	—	14	—	—	—	—	V4-T1-34
GBHS	15–20	1, 2	600Y/347	—	N.I.T.U.	—	—	—	—	—	—	10	—	—	V4-T1-34
GDB	15–50	2	480	125/250	N.I.T.U.	—	—	—	—	14	—	—	10	—	V4-T2-262
GDB	15–100	3	480	250	N.I.T.U.	—	—	—	—	14	—	—	10	—	V4-T2-262
GD	15–50	2	480	125/250	N.I.T.U.	13b	—	—	65	—	14	—	—	10	V4-T2-261
GD	15–100	3	480	250	N.I.T.U.	13b	—	—	65	—	22	—	—	10	V4-T2-261
GHC	15–100	1	120	125	N.I.T.U.	12c, 13a	65	—	—	—	—	—	14	—	V4-T2-269
GHC	15–100	2, 3	240	125/250	N.I.T.U.	13b	—	—	65	—	—	—	—	1	V4-T2-269
GHC	15–100	1	277	125	N.I.T.U.	12c, 13a	—	—	—	14	—	—	14	—	V4-T2-269
GHC	15–100	2, 3	480Y/277	125/250	N.I.T.U.	13b	—	—	—	14	14	—	—	14	V4-T2-269
HGHC	15–30	1	277	125	N.I.T.U.	—	65	—	—	25	—	—	14	—	V4-T2-269

Notes

- ① N.I.T.U. is non-interchangeable trip unit and I.T.U. is interchangeable trip unit.
- ② Two-pole circuit breaker, or two poles of three-pole circuit breaker at 250 Vdc.
- ③ Single-pole breakers can be applied in DC systems up to 70 A.

F-Frame

Circuit Breaker Type	Continuous Ampere Rating at 40 °C	No. of Poles	Volts		Type of Trip ^①	Federal Specification W-C-375b	UL Listed Interrupting Ratings (rms Symmetrical Amperes)								Page Number
			AC	DC			AC (kA)				DC (kA) ^②				
							120	120/240	240	277	480	600	125	250	
EDB	100–225	2, 3	240	125	N.I.T.U.	—	—	—	22	—	—	—	10	—	V4-T2-273
EDS	100–225	2, 3	240	125	N.I.T.U.	—	—	—	42	—	—	—	10	—	V4-T2-273
ED	15–225	2, 3	240	125	N.I.T.U.	12b	—	—	65	—	—	—	10	—	V4-T2-273
EDH	100–225	2, 3	240	125	N.I.T.U.	14b	—	—	100	—	—	—	10	—	V4-T2-273
EDC	100–225	2, 3	240	125	N.I.T.U.	1	—	—	200	—	—	—	10	—	V4-T2-273
EHD	15–100	1	277	125	N.I.T.U.	13a	—	—	—	14	—	—	10	—	V4-T2-273
EHD	15–100	2, 3	480	250	N.I.T.U.	13b	—	—	18	—	14	—	—	10	V4-T2-273
FDB	15–150	2, 3	600	250	N.I.T.U.	18a	—	—	18	—	14	14	—	10	V4-T2-273
FDB	15–150	4	600	250	N.I.T.U.	③	—	—	18	—	14	14	—	10	V4-T2-273
FD	15–150	1	277	125	N.I.T.U.	13a	—	—	—	35	—	—	10	—	V4-T2-273
FD	15–225	2, 3	600	250	N.I.T.U.	22a	—	—	65	—	35	18	—	10	V4-T2-273
FD	15–225	4	600	250	N.I.T.U.	③	—	—	65	—	35	18	—	10	V4-T2-273
FDE	15–225	3	600	—	N.I.T.U.	—	—	—	65	—	35	18	—	—	V4-T2-273
HFD	15–150	1	277	125	N.I.T.U.	13a	—	—	—	65	—	—	10	—	V4-T2-273
HFD	15–225	2,3	600	250	N.I.T.U.	22a	—	—	100	—	65	25	—	22	V4-T2-273
HFD	15–225	4	600	250	N.I.T.U.	③	—	—	100	—	65	25	—	22	V4-T2-273
HFDE	15–225	3	600	—	N.I.T.U.	—	—	—	100	—	65	25	—	—	V4-T2-273
FDC ^④	15–225	2, 3	600	250	N.I.T.U.	24a	—	—	200	—	100	35	—	22	V4-T2-273
FDC ^④	15–225	4	600	250	N.I.T.U.	③	—	—	200	—	100	35	—	22	V4-T2-273
FDCE ^{④⑤}	15–225	3	600	—	N.I.T.U.	—	—	—	200	—	100	25	—	—	V4-T2-273

Notes

- ① N.I.T.U. is non-interchangeable trip unit and I.T.U. is interchangeable trip unit.
 ② Two-pole circuit breaker, or two poles of three-pole circuit breaker at 250 Vdc.
 ③ Not defined in W-C-375b.
 ④ Current limiting.
 ⑤ Check with Eaton for availability.

2.4

Molded Case Circuit Breakers

Series C

2

J-Frame

Circuit Breaker Type	Continuous Ampere Rating at 40 °C	No. of Poles	Volts		Type of Trip ①	Federal Specification W-C-375b	UL Listed Interrupting Ratings (rms Symmetrical Amperes)								Page Number
			AC	DC			AC (kA)				DC (kA) ②				
							120	120/240	240	277	480	600	125	250	
JDB	70–250	2, 3	600	250	N.I.T.U.	22a	—	—	65	—	35	18	—	10	V4-T2-294
JD	70–250	2, 3, 4	600	250	I.T.U.	22a	—	—	65	—	35	18	—	10	V4-T2-293
HJD	70–250	2, 3, 4	600	250	I.T.U.	22a	—	—	100	—	65	25	—	22	V4-T2-293
JDC ③	70–250	2, 3, 4	600	250	I.T.U.	22a	—	—	200	—	100	35	—	22	V4-T2-293

K-Frame

Circuit Breaker Type	Continuous Ampere Rating at 40 °C	No. of Poles	Volts		Type of Trip ①	Federal Specification W-C-375b	UL Listed Interrupting Ratings (rms Symmetrical Amperes)								Page Number
			AC	DC			AC (kA)				DC (kA) ②				
							120	120/240	240	277	480	600	125	250	
DK	250–400	2, 3	240	250	N.I.T.U.	14b	—	—	65	—	—	—	—	10	V4-T2-305
KDB	100–400	2, 3	600	250	N.I.T.U.	23a	—	—	65	—	35	25	—	10	V4-T2-305
KD	100–400	2, 3, 4	600	250	I.T.U.	23a	—	—	65	—	35	25	—	10	V4-T2-302, V4-T2-303, V4-T2-307, V4-T2-310
CKD	100–400	2, 3, 4	600	250	I.T.U.	23a	—	—	65	—	35	25	—	—	V4-T2-304, V4-T2-313, V4-T2-315
HKD	100–400	2, 3, 4	600	250	I.T.U.	23a	—	—	100	—	65	35	—	22	V4-T2-302, V4-T2-303, V4-T2-307, V4-T2-310
CHKD	100–400	2, 3, 4	600	250	I.T.U.	23a	—	—	100	—	65	35	—	—	V4-T2-304, V4-T2-313, V4-T2-315
KDC ③	100–400	2, 3, 4	600	250	I.T.U.	23a	—	—	200	—	100	65	—	22	V4-T2-302, V4-T2-303, V4-T2-307, V4-T2-310

L-Frame

Circuit Breaker Type	Continuous Ampere Rating at 40 °C	No. of Poles	Volts		Type of Trip ①	Federal Specification W-C-375b	UL Listed Interrupting Ratings (rms Symmetrical Amperes)								Page Number
			AC	DC			AC (kA)				DC (kA) ②				
							120	120/240	240	277	480	600	125	250	
LDB	300–600	2, 3	600	250	N.I.T.U.	23a	—	—	65	—	35	25	—	22	V4-T2-328
LD	300–600	2, 3, 4	600	250	I.T.U.	23a	—	—	65	—	35	25	—	22	V4-T2-326, V4-T2-327, V4-T2-332
CLD	300–600	2, 3, 4	600	250	I.T.U.	23a	—	—	65	—	35	25	—	—	V4-T2-328, V4-T2-338
HLD	300–600	2, 3, 4	600	250	I.T.U.	23a	—	—	100	—	65	35	—	25	V4-T2-326, V4-T2-327, V4-T2-332
CHLD	300–600	2, 3, 4	600	250	I.T.U.	23a	—	—	100	—	65	35	—	—	V4-T2-328, V4-T2-338
LDC ③	300–600	2, 3, 4	600	250	I.T.U.	23a	—	—	200	—	100	50	—	30	V4-T2-326, V4-T2-327, V4-T2-334
CLDC ③	300–600	2, 3, 4	600	250	I.T.U.	23a	—	—	200	—	100	50	—	30	V4-T2-328, V4-T2-340

M-Frame

Circuit Breaker Type	Continuous Ampere Rating at 40 °C	No. of Poles	Volts		Type of Trip ①	Federal Specification W-C-375b	UL Listed Interrupting Ratings (rms Symmetrical Amperes)								Page Number
			AC	DC			AC (kA)				DC (kA) ②				
							120	120/240	240	277	480	600	125	250	
MDL	300–800	2, 3	600	250	I.T.U.	23a	—	—	65	—	50	25	—	22	V4-T2-351, V4-T2-353
CMDL	300–800	2, 3	600	250	I.T.U.	23a	—	—	65	—	50	25	—	—	V4-T2-353
HMDL	300–800	2, 3	600	250	I.T.U.	23a	—	—	100	—	65	35	—	25	V4-T2-351, V4-T2-353
CHMDL	300–800	2, 3	600	250	I.T.U.	23a	—	—	100	—	65	35	—	—	V4-T2-353

Notes

① N.I.T.U. is non-interchangeable trip unit and I.T.U. is interchangeable trip unit.

② Two-pole circuit breaker, or two poles of three-pole circuit breaker at 250 Vdc.

③ Current limiting.

Molded Case Circuit Breaker Product Family**Contents****Description**

	Page
Product Overview	V4-T2-254
Standards and Certifications	V4-T2-255
Quick Reference	V4-T2-256
G-Frame (15–100 Amperes)	
Catalog Number Selection	V4-T2-260
Technical Data and Specifications	V4-T2-260
F-Frame (10–225 Amperes)	V4-T2-273
J-Frame (70–250 Amperes)	V4-T2-291
K-Frame (70–400 Amperes)	V4-T2-299
L-Frame (125–600 Amperes)	V4-T2-323
M-Frame (300–800 Amperes)	V4-T2-349
N-Frame (400–1200 Amperes)	V4-T2-360
R-Frame (800–2500 Amperes)	V4-T2-375
Motor Circuit Protectors (MCP)	V4-T2-394
Motor Protection Circuit Breakers (MPCB)	V4-T2-405
Type ELC Current Limiter Attachment (Size 0–4)	V4-T2-407
Current Limiting Circuit Breaker Module	V4-T2-408
Internal Accessories	V4-T2-411
External Accessories	V4-T2-444

G-Frame (15–100 Amperes)**Product Description**

- All two- and three-pole circuit breakers are of the common trip type. On all three-phase delta (240 V) Grounded B phase applications, refer to Eaton
- Single-pole circuit breakers, 15 and 20 amperes. Switching duty rated (SWD) for fluorescent lighting applications
- All G-Frame circuit breakers are suitable for reverse feed use
- HACR rated

Catalog Number Selection

This information is presented only as an aid to understanding catalog numbers. It is not to be used to build catalog numbers for circuit breakers or trip units.

2

Circuit Breaker/Frame

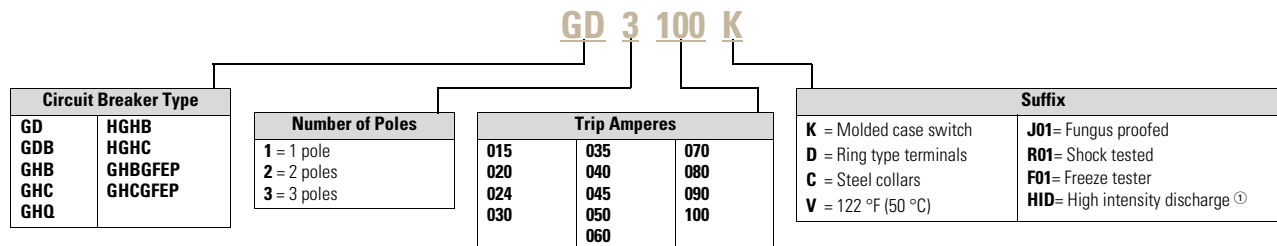

Technical Data and Specifications

UL 489 Interrupting Capacity Ratings

Circuit Breaker Type	Number of Poles	Interrupting Capacity (kA Symmetrical Amperes)						
		Volts AC (50/60 Hz)					Volts DC	
		120	240	277	480	480Y/277	125 ^②	250 ^{③④}
GDB	2, 3	—	—	—	14	—	—	10
GD	2	—	65	—	14	—	—	10
GD	3	—	65	—	22	—	—	10
GHQ	—	65	—	14	—	—	—	—
GHB	1	65	—	14	—	—	14	—
GHB	2, 3	—	65	—	—	14	14	—
HGHB	1	65	—	25	—	—	14	—
GHC	1	65	—	14	—	—	14	—
GHC	2, 3	—	65	—	—	14	14	—
HGHC	1	65	—	25	—	—	14	—

Terminal Types

For line and load-side. Terminals are UL listed as suitable for wire type and size given below.

Terminal Types

Circuit Breaker Amperes	Terminal Type Material	Screw Head Type	Wire Type	AWG Wire Range	Metric Wire Range (mm ²) ^⑤
Standard					
15–20	Clamp (plated steel)	Slotted	Cu/Al	14–10	2.5–4
25–100	Pressure (aluminum body)	Slotted	Cu/Al	10–1/0	4–50
Optional—GD, GHB, GHC					
15–100	Pressure (steel body)	Slotted	Cu	14–3	—

Notes

- ① HID suffix only applies to the GHB and GHC single-pole, 15–20 A circuit breakers.
- ② Single-pole breakers can be applied in DC systems up to 70 A.
- ③ Time constant is 8 milliseconds minimum.
- ④ Two poles of three-pole circuit breaker.
- ⑤ Not UL listed sizes.

Typical G-Frame Circuit Breaker



Contents

Description

Product Overview	V4-T2-254
Standards and Certifications	V4-T2-255
Quick Reference	V4-T2-256
G-Frame (15–100 Amperes)	V4-T2-259
F-Frame (10–225 Amperes)	V4-T2-273
J-Frame (70–250 Amperes)	V4-T2-291
K-Frame (70–400 Amperes)	V4-T2-299
L-Frame (125–600 Amperes)	V4-T2-323
M-Frame (300–800 Amperes)	V4-T2-349
N-Frame (400–1200 Amperes)	V4-T2-360
R-Frame (800–2500 Amperes)	V4-T2-375
Motor Circuit Protectors (MCP)	V4-T2-394
Motor Protection Circuit Breakers (MPCB)	V4-T2-405
Type ELC Current Limiter Attachment (Size 0–4)	V4-T2-407
Current Limiting Circuit Breaker Module	V4-T2-408
Internal Accessories	V4-T2-411
External Accessories	V4-T2-444

Type GD Thermal-Magnetic Circuit Breakers with Non-Interchangeable Trip Units (15–100 Amperes)

Product Description

- Cable in, cable out
- Includes mounting hardware and BMHE

Standards and Certifications

- UL/CSA



Product Selection

Type GD Thermal-Magnetic Circuit Breakers with Non-Interchangeable Trip Units

Maximum Continuous Ampere Rating at 40 °C	480 Vac Maximum, 250 Vdc		Includes Binding Head Screws and Clamps 10–32 x 0.312
	14 kAIC at 480 Vac	22 kAIC at 480 Vac	
	Includes Line and Load Terminals		
	Two-Pole Catalog Number	Three-Pole Catalog Number	Three-Pole Catalog Number
15	GD2015	GD3015	GD3015D
20	GD2020	GD3020	GD3020D
25	GD2025	GD3025	GD3025D
30	GD2030	GD3030	GD3030D
35	GD2035	GD3035	GD3035D
40	GD2040	GD3040	GD3040D
45	GD2045	GD3045	GD3045D
50	GD2050	GD3050	GD3050D
60	—	GD3060	GD3060D
70	—	GD3070	GD3070D
80	—	GD3080	GD3080D
90	—	GD3090	GD3090D
100	—	GD3100	GD3100D

Type GDB Thermal-Magnetic Circuit Breakers with Non-Interchangeable Trip Units

Maximum Continuous Ampere Rating at 40 °C	480 Vac Maximum, 250 Vdc 14 kAIC at 480 Vac Includes Line and Load Terminals	
	Two-Pole Catalog Number	Three-Pole Catalog Number
15	GDB2015	GDB3015
20	GDB2020	GDB3020
25	GDB2025	GDB3025
30	GDB2030	GDB3030
35	GDB2035	GDB3035
40	GDB2040	GDB3040
45	GDB2045	GDB3045
50	GDB2050	GDB3050
60	—	GDB3060
70	—	GDB3070
80	—	GDB3080
90	—	GDB3090
100	—	GDB3100

Type GD Molded Case Switches

Type GD Molded Case Switches—Three-Pole

Maximum Continuous Ampere Rating at 40 °C	480 Vac Maximum, 250 Vdc
	Catalog Number (Includes Line and Load Terminals)
60	GD3060K
60	GD3060KC ①
100	GD3100K
100	GD3100KD ②

Notes

① Includes line and load steel terminals.

② Includes binding head screws and clamps 10–32 x 0.312.

Molded case switches may open above 1300 amperes.

Dimensions

Approximate Dimensions in Inches (mm)

GD-Frame, Three-Pole

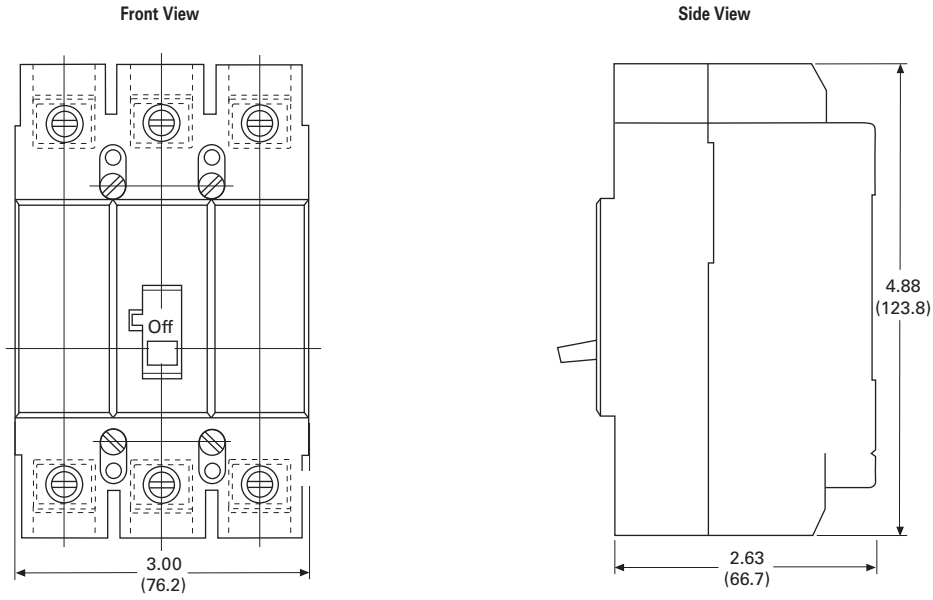

Typical GHB

2



Contents

<i>Description</i>	<i>Page</i>
Product Overview	V4-T2-254
Standards and Certifications	V4-T2-255
Quick Reference	V4-T2-256
G-Frame (15–100 Amperes)	V4-T2-259
F-Frame (10–225 Amperes)	V4-T2-273
J-Frame (70–250 Amperes)	V4-T2-291
K-Frame (70–400 Amperes)	V4-T2-299
L-Frame (125–600 Amperes)	V4-T2-323
M-Frame (300–800 Amperes)	V4-T2-349
N-Frame (400–1200 Amperes)	V4-T2-360
R-Frame (800–2500 Amperes)	V4-T2-375
Motor Circuit Protectors (MCP)	V4-T2-394
Motor Protection Circuit Breakers (MPCB)	V4-T2-405
Type ELC Current Limiter Attachment (Size 0–4)	V4-T2-407
Current Limiting Circuit Breaker Module	V4-T2-408
Internal Accessories	V4-T2-411
External Accessories	V4-T2-444

Types GHB and HGHB Bolt-On Panelboard Circuit Breakers (15–100 Amperes)

Standards and Certifications

These breakers meet the requirements of Federal Specification W-C-375b as follows:

- Type GHB, 120 and 240 V:
 - Single-pole: Class 11a
 - Two-, three-pole: Classes 10b, 11b, 12b, 14b, 15b
 - UL/CSA
- Type GHB, 277 and 480Y/277 V:
 - Single-pole: Classes 12c, 13a
 - Two-, three-pole: Class 13b
 - Type HGHB 277 V
 - Type GHQ 277 V



Product Selection

Typical GHB

Type GHB Thermal-Magnetic Circuit Breakers with Non-Interchangeable Trip Units ^①

Continuous Ampere Rating at 40 °C	277/480 Vac Maximum, 125 Vdc Maximum ^②	277/480 Vac Maximum, 125/250 Vdc Maximum	277/480 Vac Maximum, 125/250 Vdc Maximum ^③
	Single-Pole Catalog Number	Two-Pole Catalog Number	Three-Pole Catalog Number
15	GHB1015 ^{④⑤}	GHB2015 ^④	GHB3015 ^④
20	GHB1020 ^{④⑤}	GHB2020 ^④	GHB3020 ^④
25	GHB1025	GHB2025	GHB3025
30	GHB1030	GHB2030	GHB3030
35	GHB1035	GHB2035	GHB3035
40	GHB1040	GHB2040	GHB3040
45	GHB1045	GHB2045	GHB3045
50	GHB1050	GHB2050	GHB3050
60	GHB1060	GHB2060	GHB3060
70	GHB1070	GHB2070	GHB3070
80	GHB1080	GHB2080	GHB3080
90	GHB1090	GHB2090	GHB3090
100	GHB1100	GHB2100	GHB3100

Type HGHB Thermal-Magnetic Circuit Breakers with Non-Interchangeable Trip Units

Continuous Ampere Rating at 40 °C	277 Vac Maximum, 125 Vdc Maximum Single-Pole Catalog Number
	15
20	HGHB1020 ^⑥
25	HGHB1025
30	HGHB1030

Notes

- ① 480Y/277 V, circuit breakers (Type GHB) not suitable for three-phase delta (480 V).
- ② Single-pole breakers can be applied in DC systems from 15 through 70 amperes; 80 through 100 amperes devices are not suitable for DC application.
- ③ Use two outside poles.
- ④ Uses 0.190 (4.83) –32 screw type clamp terminals.
- ⑤ Add suffix HID for High Intensity Discharge (HID) applications. 15 and 20 ampere, single-pole are SWD rated.
- ⑥ 15 and 20 ampere, single-pole are SWD rated.

2.4

Molded Case Circuit Breakers

Series C

Dimensions

Approximate Dimensions in Inches (mm)

2

GDB-Frame, Three-Pole

Front View

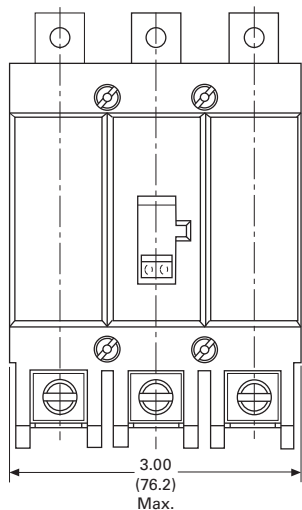

Side View

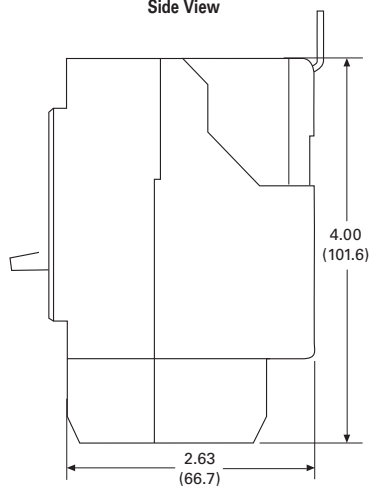

Single-Phase (requires two poles)



Contents

<i>Description</i>	<i>Page</i>
Product Overview	V4-T2-254
Standards and Certifications	V4-T2-255
Quick Reference	V4-T2-256
G-Frame (15–100 Amperes)	V4-T2-259
F-Frame (10–225 Amperes)	V4-T2-273
J-Frame (70–250 Amperes)	V4-T2-291
K-Frame (70–400 Amperes)	V4-T2-299
L-Frame (125–600 Amperes)	V4-T2-323
M-Frame (300–800 Amperes)	V4-T2-349
N-Frame (400–1200 Amperes)	V4-T2-360
R-Frame (800–2500 Amperes)	V4-T2-375
Motor Circuit Protectors (MCP)	V4-T2-394
Motor Protection Circuit Breakers (MPCB)	V4-T2-405
Type ELC Current Limiter Attachment (Size 0–4)	V4-T2-407
Current Limiting Circuit Breaker Module	V4-T2-408
Internal Accessories	V4-T2-411
External Accessories	V4-T2-444

Type GHBGFEP Bolt-On Panelboard 30 mA Industrial Ground Fault Circuit Protectors (15–100 Amperes)

Product Description

- 15–60 amperes, 277 V, 50/60 Hz
- Operational voltage 240 V to 305 V

Standards and Certifications

These circuit breakers meet the requirements of UL 489 and UL 1053.



Product Selection

Type GHBGFEP Bolt-On Panelboard 30 mA Industrial Ground Fault Circuit Protectors with Non-Interchangeable Trip Units

Continuous Ampere Rating at 40 °C	Single-Phase (Requires Two Poles) 277 Vac, 30 mA Catalog Number
15	GHBGFEP1015
20	GHBGFEP1020
30	GHBGFEP1030
40	GHBGFEP1040
50	GHBGFEP1050
60	GHBGFEP1060

Technical Data and Specifications

Interrupting Capacity Ratings

Circuit Breaker Type	Number of Poles	Interrupting Capacity (Symmetrical Amperes) 277 Vac (50/60 Hz)
GHBGFEP	1	14,000

2.4

Molded Case Circuit Breakers

Series C

Dimensions

Approximate Dimensions in Inches (mm)

2

GHB-Frame, Three-Pole

Front View

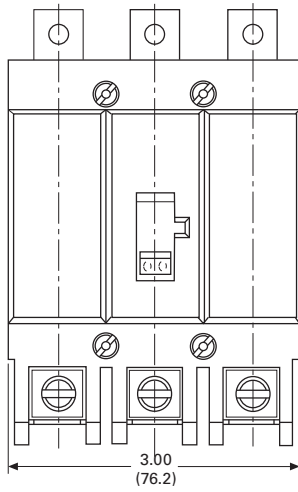

Side View

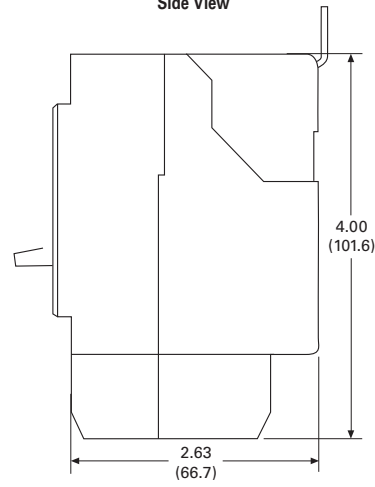

Typical GHC



Contents

Description

	<i>Page</i>
Product Overview	V4-T2-254
Standards and Certifications	V4-T2-255
Quick Reference	V4-T2-256
G-Frame (15–100 Amperes)	V4-T2-259
F-Frame (10–225 Amperes)	V4-T2-273
J-Frame (70–250 Amperes)	V4-T2-291
K-Frame (70–400 Amperes)	V4-T2-299
L-Frame (125–600 Amperes)	V4-T2-323
M-Frame (300–800 Amperes)	V4-T2-349
N-Frame (400–1200 Amperes)	V4-T2-360
R-Frame (800–2500 Amperes)	V4-T2-375
Motor Circuit Protectors (MCP)	V4-T2-394
Motor Protection Circuit Breakers (MPCB)	V4-T2-405
Type ELC Current Limiter Attachment (Size 0–4)	V4-T2-407
Current Limiting Circuit Breaker Module	V4-T2-408
Internal Accessories	V4-T2-411
External Accessories	V4-T2-444

Types GHC and HGHC Circuit Breakers (15–100 Amperes)

Product Description

- 15–100 amperes
- 120, 240, 277, 480Y/277 V, 50/60 Hz, 125, 125/250 Vdc
- Single-, two- and three-pole
- Cable in, cable out
- Does not include mounting hardware

Standards and Certifications

These breakers meet the requirements of Federal Specification W-C-37b as follows:

- Type GHC, 277 and 480Y/277 V:
 - Single-pole: Classes 12c, 13a
 - Two-, three-pole: Class 13b
- UL/CSA



Product Selection

2

Type GHC Thermal-Magnetic Circuit Breakers with Non-Interchangeable Trip Units

Continuous Ampere Rating at 40 °C	277 Vac Maximum, 125 Vdc Maximum ^①	480Y/277 Vac Maximum, 125/250 Vdc Maximum	480Y/277 Vac Maximum, 125/250 Vdc Maximum ^②
	Single-Pole Catalog Number	Two-Pole Catalog Number	Three-Pole Catalog Number
15	GHC1015 ^{③④}	GHC2015 ^③	GHC3015 ^③
20	GHC1020 ^{③④}	GHC2020 ^③	GHC3020 ^③
25	GHC1025	GHC2025	GHC3025
30	GHC1030	GHC2030	GHC3030
35	GHC1035	GHC2035	GHC3035
40	GHC1040	GHC2040	GHC3040
45	GHC1045	GHC2045	GHC3045
50	GHC1050	GHC2050	GHC3050
60	GHC1060	GHC2060	GHC3060
70	GHC1070	GHC2070	GHC3070
80	GHC1080	GHC2080	GHC3080
90	GHC1090	GHC2090	GHC3090
100	GHC1100	GHC2100	GHC3100

Type HGHC Thermal-Magnetic Circuit Breakers with Non-Interchangeable Trip Units

Continuous Ampere Rating at 40 °C	277 Vac Maximum, 125 Vdc Maximum
	Single-Pole Catalog Number
15	HGHC1015 ^⑤
20	HGHC1020 ^⑤
25	HGHC1025
30	HGHC1030

Notes

- ① 15 through 70 ampere circuit breakers only.
- ② Single-pole breakers can be applied in DC systems from 15 through 70 ampere; 80 through 100 ampere devices are not suitable for DC application.
- ③ Uses 0.190–32 screw type clamp terminals.
- ④ Add suffix HID for High Intensity Discharge (HID) applications. 15 and 20 ampere, single-pole are SWD rated.
- ⑤ 15 and 20 ampere, single-pole are SWD rated.

Single-Phase (requires two-pole spaces)



Contents

<i>Description</i>	<i>Page</i>
Product Overview	V4-T2-254
Standards and Certifications	V4-T2-255
Quick Reference	V4-T2-256
G-Frame (15–100 Amperes)	V4-T2-259
F-Frame (10–225 Amperes)	V4-T2-273
J-Frame (70–250 Amperes)	V4-T2-291
K-Frame (70–400 Amperes)	V4-T2-299
L-Frame (125–600 Amperes)	V4-T2-323
M-Frame (300–800 Amperes)	V4-T2-349
N-Frame (400–1200 Amperes)	V4-T2-360
R-Frame (800–2500 Amperes)	V4-T2-375
Motor Circuit Protectors (MCP)	V4-T2-394
Motor Protection Circuit Breakers (MPCB)	V4-T2-405
Type ELC Current Limiter Attachment (Size 0–4)	V4-T2-407
Current Limiting Circuit Breaker Module	V4-T2-408
Internal Accessories	V4-T2-411
External Accessories	V4-T2-444

Type GHCGFEP Cable-In/Cable-Out 30 mA Industrial Ground Fault Circuit Protectors (15–100 Amperes)

Product Description

- 15–60 amperes, 277 V, 50/60 Hz
- Operational voltage 240–305 V

Standards and Certifications

These circuit breakers meet the requirements of UL 489 and UL 1053.



Product Selection

Type GHCGFEP 30 mA Industrial Ground Fault Circuit Protectors with Non-Interchangeable Trip Units

Continuous Ampere Rating at 40 °C	Single-Phase (Requires Two Poles) 277 V, 30 mA Catalog Number
15	GHCGFEP1015
20	GHCGFEP1020
30	GHCGFEP1030
40	GHCGFEP1040
50	GHCGFEP1050
60	GHCGFEP1060

Technical Data and Specifications

Interrupting Capacity Ratings

Circuit Breaker Type	Number of Poles	Interrupting Capacity (Symmetrical Amperes) 277 Vac (50/60 Hz)
GHCGFEP	1	14,000

Special Purpose Circuit Breakers

2



Contents

<i>Description</i>	<i>Page</i>
Product Overview	V4-T2-254
Standards and Certifications	V4-T2-255
Quick Reference	V4-T2-256
G-Frame (15–100 Amperes)	V4-T2-259
F-Frame (10–225 Amperes)	V4-T2-273
J-Frame (70–250 Amperes)	V4-T2-291
K-Frame (70–400 Amperes)	V4-T2-299
L-Frame (125–600 Amperes)	V4-T2-323
M-Frame (300–800 Amperes)	V4-T2-349
N-Frame (400–1200 Amperes)	V4-T2-360
R-Frame (800–2500 Amperes)	V4-T2-375
Motor Circuit Protectors (MCP)	V4-T2-394
Motor Protection Circuit Breakers (MPCB)	V4-T2-405
Type ELC Current Limiter Attachment (Size 0–4)	V4-T2-407
Current Limiting Circuit Breaker Module	V4-T2-408
Internal Accessories	V4-T2-411
External Accessories	V4-T2-444

Special Purpose GHC Circuit Breakers (15–100 Amperes)

Product Description

Eaton’s Type GHC circuit breakers have binding head screw-type terminals on line and load side. These circuit breakers with screw-type terminals (0.190–32) will be marked “Special purpose breaker not for general use.” To order this special breaker, use the catalog number from the tables on this page.

Product Selection

Type GHC Thermal-Magnetic Circuit Breakers with Non-Interchangeable Trip Units

Continuous Ampere Rating at 40 °C	277 Vac Maximum, 125 Vdc Maximum ①	480Y/277 Vac Maximum, 125/250 Vdc Maximum	480Y/277 Vac Maximum, 125/250 Vdc Maximum ②
	Single-Pole Catalog Number	Two-Pole Catalog Number	Three-Pole Catalog Number
25	GHC1025D	GHC2025D	GHC3025D
30	GHC1030D	GHC2030D	GHC3030D
35	GHC1035D	GHC2035D	GHC3035D
40	GHC1040D	GHC2040D	GHC3040D
45	GHC1045D	GHC2045D	GHC3045D
50	GHC1050D	GHC2050D	GHC3050D
60	GHC1060D	GHC2060D	GHC3060D
70	GHC1070D	GHC2070D	GHC3070D
80	GHC1080D	GHC2080D	GHC3080D
90	GHC1090D	GHC2090D	GHC3090D
100	GHC1100D	GHC2100D	GHC3100D

Type GHB and GHC Thermal-Magnetic Circuit Breakers with Non-Interchangeable Trip Units for HID Lighting Applications

Type	Continuous Ampere Rating at 40 °C	277 Vac Maximum Single-Pole Catalog Number
Cable-in	15	GHC1015HID
	20	GHC1020HID
Bolt-on	15	GHB1015HID
	20	GHB1020HID

Notes

- ① Single-pole breakers can be applied in DC systems from 15 through 70 amperes; 80 through 100 amperes devices are not suitable for DC application.
- ② Use two outside poles.

Typical F-Frame Breaker
F-Frame Breaker with Electronic Trip Unit



F-Frame (10–225 Amperes)

Product Description

- All Eaton's F-Frame circuit breakers are HACR rated
- All circuit breakers 10 through 30 amperes are suitable for HID (high intensity discharge) use
- All F-Frame circuit breakers are suitable for reverse feed use

Contents

Description

	<i>Page</i>
Product Overview	V4-T2-254
Standards and Certifications	V4-T2-255
Quick Reference	V4-T2-256
G-Frame (15–100 Amperes)	V4-T2-259
F-Frame (10–225 Amperes)	
Catalog Number Selection	V4-T2-274
Product Selection	V4-T2-276
Accessories	V4-T2-287
Technical Data and Specifications	V4-T2-288
Dimensions and Weights	V4-T2-290
J-Frame (70–250 Amperes)	V4-T2-291
K-Frame (70–400 Amperes)	V4-T2-299
L-Frame (125–600 Amperes)	V4-T2-323
M-Frame (300–800 Amperes)	V4-T2-349
N-Frame (400–1200 Amperes)	V4-T2-360
R-Frame (800–2500 Amperes)	V4-T2-375
Motor Circuit Protectors (MCP)	V4-T2-394
Motor Protection Circuit Breakers (MPCB)	V4-T2-405
Type ELC Current Limiter Attachment (Size 0–4)	V4-T2-407
Current Limiting Circuit Breaker Module	V4-T2-408
Internal Accessories	V4-T2-411
External Accessories	V4-T2-444

2.4

Molded Case Circuit Breakers

Series C

Catalog Number Selection

This information is presented only as an aid to understanding catalog numbers. It is not to be used to build catalog numbers for circuit breakers or trip units.

2

FD-Frame Circuit Breakers with Thermal-Magnetic Trip Unit Technology

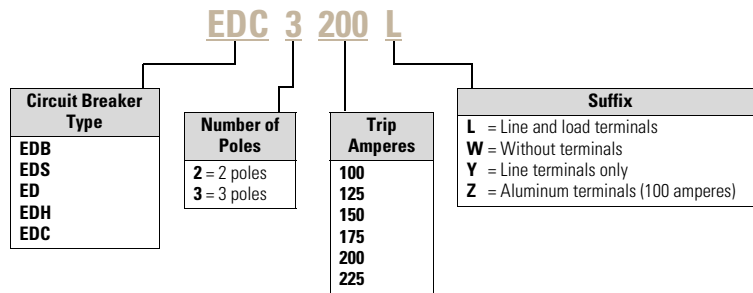
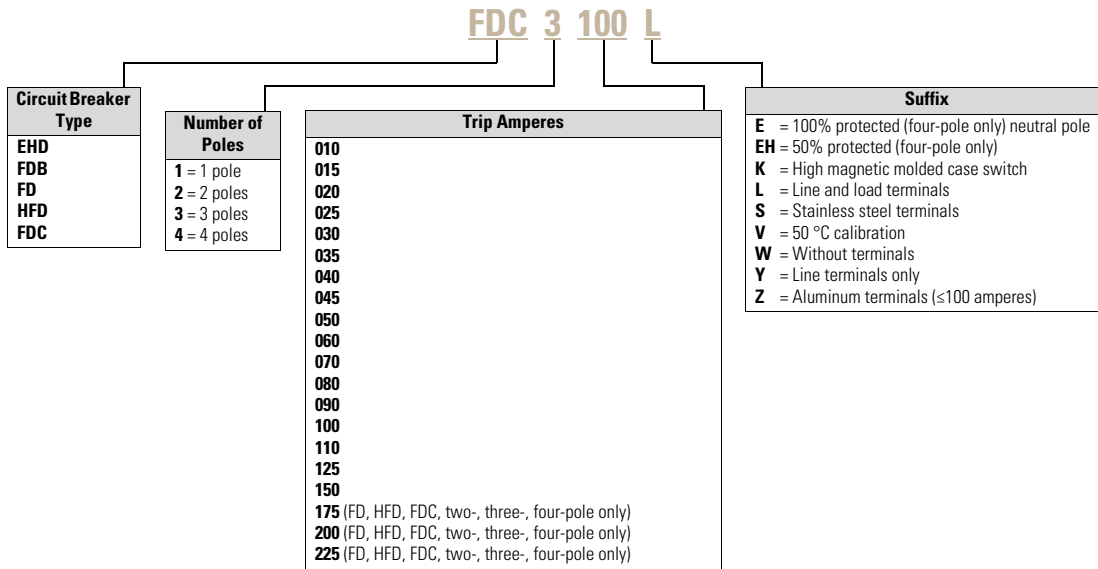

This information is presented only as an aid to understanding catalog numbers. It is not to be used to build catalog numbers for circuit breakers or trip units.

FD-Frame Circuit Breakers with 210+ Electronic Trip Unit Technology

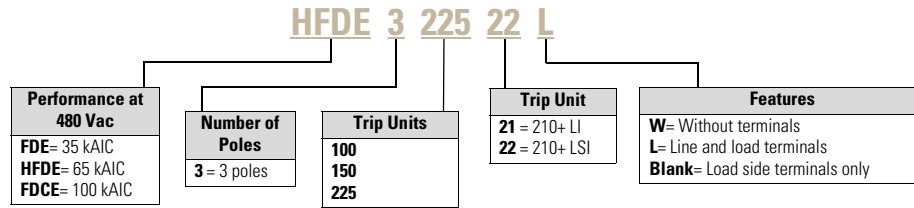

FD-Frame Circuit Breakers with 310+ Electronic Trip Unit Technology

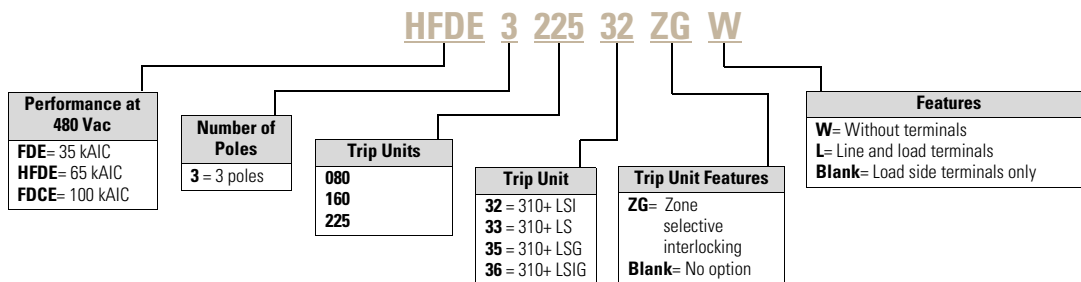

Product Selection

2

Type ED Thermal-Magnetic Circuit Breakers with Non-Interchangeable Trip Units Suitable for Reverse Feed

Maximum Continuous Ampere Rating at 40 °C	240 Vac Maximum, 125 Vdc (Includes Terminals on Load End Only) 65 kAIC at 240 Vac	
	Two-Pole Catalog Number	Three-Pole Catalog Number
15	ED2015	ED3015
20	ED2020	ED3020
25	ED2025	ED3025
30	ED2030	ED3030
35	ED2035	ED3035
40	ED2040	ED3040
50	ED2050	ED3050
60	ED2060	ED3060
100	ED2100	ED3100
125	ED2125	ED3125
150	ED2150	ED3150
175	ED2175	ED3175
200	ED2200	ED3200
225	ED2225	ED3225

Type EDH Thermal-Magnetic Circuit Breakers with Non-Interchangeable Trip Units Suitable for Reverse Feed

Maximum Continuous Ampere Rating at 40 °C	240 Vac Maximum, 125 Vdc (Includes Terminals on Load End Only) 100 kAIC at 240 Vac	
	Two-Pole Catalog Number	Three-Pole Catalog Number
15	—	—
20	—	—
25	—	—
30	—	—
35	—	—
40	—	—
50	—	—
60	—	—
100	EDH2100	EDH3100
125	EDH2125	EDH3125
150	EDH2150	EDH3150
175	EDH2175	EDH3175
200	EDH2200	EDH3200
225	EDH2225	EDH3225

Type EDC Thermal-Magnetic Circuit Breakers with Non-Interchangeable Trip Units Suitable for Reverse Feed

Maximum Continuous Ampere Rating at 40 °C	240 Vac Maximum, 125 Vdc (Includes Terminals on Load End Only) 200 kAIC at 240 Vac	
	Two-Pole Catalog Number	Three-Pole Catalog Number
15	—	—
20	—	—
25	—	—
30	—	—
35	—	—
40	—	—
50	—	—
60	—	—
100	EDC2100	EDC3100
125	EDC2125	EDC3125
150	EDC2150	EDC3150
175	EDC2175	EDC3175
200	EDC2200	EDC3200
225	EDC2225	EDC3225

Type EDB Thermal-Magnetic Circuit Breakers with Non-Interchangeable Trip Units Suitable for Reverse Feed

Maximum Continuous Ampere Rating at 40 °C	240 Vac Maximum, 125 Vdc (Includes Terminals on Load End Only) 22 kAIC at 240 Vac	
	Two-Pole Catalog Number	Three-Pole Catalog Number
100	EDB2100	EDB3100
110	EDB2110	EDB3110
125	EDB2125	EDB3125
150	EDB2150	EDB3150
175	EDB2175	EDB3175
200	EDB2200	EDB3200
225	EDB2225	EDB3225

Type EDS Thermal-Magnetic Circuit Breakers with Non-Interchangeable Trip Units Suitable for Reverse Feed

Maximum Continuous Ampere Rating at 40 °C	240 Vac Maximum, 125 Vdc (Includes Terminals on Load End Only) 42 kAIC at 240 Vac	
	Two-Pole Catalog Number	Three-Pole Catalog Number
100	EDS2100	EDS3100
110	EDS2110	EDS3110
125	EDS2125	EDS3125
150	EDS2150	EDS3150
175	EDS2175	EDS3175
200	EDS2200	EDS3200
225	EDS2225	EDS3225

Type EHD Thermal-Magnetic Circuit Breakers with Non-Interchangeable Trip Units (Includes Terminals on Load End Only)

Maximum Continuous Ampere Rating at 40 °C	277 Vac Maximum, 125 Vdc 14 kAIC at 277 Vac Single-Pole	480 Vac Maximum, 250 Vdc 14 kAIC at 480 Vac Two-Pole	Three-Pole
	Catalog Number	Catalog Number	Catalog Number
10 ①	EHD1010	EHD2010	EHD3010
15	EHD1015 ②	EHD2015	EHD3015
20	EHD1020 ②	EHD2020	EHD3020
25	EHD1025	EHD2025	EHD3025
30	EHD1030	EHD2030	EHD3030
35	EHD1035	EHD2035	EHD3035
40	EHD1040	EHD2040	EHD3040
45	EHD1045	EHD2045	EHD3045
50	EHD1050	EHD2050	EHD3050
60	EHD1060	EHD2060	EHD3060
70	EHD1070	EHD2070	EHD3070
80	EHD1080	EHD2080	EHD3080
90	EHD1090	EHD2090	EHD3090
100	EHD1100	EHD2100	EHD3100

Notes

- ① Not UL listed. 5 kAIC interrupting rating.
- ② UL listed for SWD applications, see NEC Article 240.83(d).

**Type FDB Thermal-Magnetic Circuit Breakers with Non-Interchangeable Trip Units
(Includes Terminals on Load End Only)**

Maximum Continuous Ampere Rating at 40 °C	600 Vac Maximum, 250 Vdc 14 kAIC at 600 Vac		
	Two-Pole Catalog Number	Three-Pole Catalog Number	Four-Pole Catalog Number
10 ①	FDB2010	FDB3010	FDB4010
15	FDB2015	FDB3015	FDB4015
20	FDB2020	FDB3020	FDB4020
25	FDB2025	FDB3025	FDB4025
30	FDB2030	FDB3030	FDB4030
35	FDB2035	FDB3035	FDB4035
40	FDB2040	FDB3040	FDB4040
45	FDB2045	FDB3045	FDB4045
50	FDB2050	FDB3050	FDB4050
60	FDB2060	FDB3060	FDB4060
70	FDB2070	FDB3070	FDB4070
80	FDB2080	FDB3080	FDB4080
90	FDB2090	FDB3090	FDB4090
100	FDB2100	FDB3100	FDB4100
110	FDB2110	FDB3110	FDB4110
125	FDB2125	FDB3125	FDB4125
150	FDB2150	FDB3150	FDB4150

Note

① Not UL listed. 5 kAIC interrupting rating.

**Type FD Thermal-Magnetic Circuit Breakers with Non-Interchangeable Trip Units
(Includes Terminals on Load End Only)**

2

Maximum Continuous Ampere Rating at 40 °C	277 Vac Maximum, 125 Vdc 35 kAIC at 277 Vac	600 Vac Maximum, 250 Vdc 35 kAIC at 480 Vac		
	Single-Pole Catalog Number	Two-Pole Catalog Number	Three-Pole Catalog Number	Four-Pole Catalog Number
10 ①	FD1010	—	—	—
15	FD1015 ②	FD2015	FD3015	FD4015
20	FD1020 ②	FD2020	FD3020	FD4020
25	FD1025	FD2025	FD3025	FD4025
30	FD1030	FD2030	FD3030	FD4030
35	FD1035	FD2035	FD3035	FD4035
40	FD1040	FD2040	FD3040	FD4040
45	FD1045	FD2045	FD3045	FD4045
50	FD1050	FD2050	FD3050	FD4050
60	FD1060	FD2060	FD3060	FD4060
70	FD1070	FD2070	FD3070	FD4070
80	FD1080	FD2080	FD3080	FD4080
90	FD1090	FD2090	FD3090	FD4090
100	FD1100	FD2100	FD3100	FD4100
110	FD1110	FD2110	FD3110	FD4110
125	FD1125	FD2125	FD3125	FD4125
150	FD1150	FD2150	FD3150	FD4150
175	—	FD2175	FD3175	FD4175
200	—	FD2200	FD3200	FD4200
225	—	FD2225	FD3225	FD4225

Notes

- ① Not UL listed. 5 kAIC interrupting rating.
 ② UL listed for SWD applications, see NEC Article 240.83(d).

**Type HFD Thermal-Magnetic Circuit Breakers with Non-Interchangeable Trip Units
(Includes Terminals on Load End Only)**

Maximum Continuous Ampere Rating at 40 °C	277 Vac Maximum, 125 Vdc 65 kAIC at 277 Vac	600 Vac Maximum, 250 Vdc 65 kAIC at 480 Vac		
	Single-Pole Catalog Number	Two-Pole Catalog Number	Three-Pole Catalog Number	Four-Pole Catalog Number
15	HFD1015 ①	HFD2015	HFD3015	HFD4015
20	HFD1020 ①	HFD2020	HFD3020	HFD4020
25	HFD1025	HFD2025	HFD3025	HFD4025
30	HFD1030	HFD2030	HFD3030	HFD4030
35	HFD1035	HFD2035	HFD3035	HFD4035
40	HFD1040	HFD2040	HFD3040	HFD4040
45	HFD1045	HFD2045	HFD3045	HFD4045
50	HFD1050	HFD2050	HFD3050	HFD4050
60	HFD1060	HFD2060	HFD3060	HFD4060
70	HFD1070	HFD2070	HFD3070	HFD4070
80	HFD1080	HFD2080	HFD3080	HFD4080
90	HFD1090	HFD2090	HFD3090	HFD4090
100	HFD1100	HFD2100	HFD3100	HFD4100
110	HFD1110	HFD2110	HFD3110	HFD4110
125	HFD1125	HFD2125	HFD3125	HFD4125
150	HFD1150	HFD2150	HFD3150	HFD4150
175	—	HFD2175	HFD3175	HFD4175
200	—	HFD2200	HFD3200	HFD4200
225	—	HFD2225	HFD3225	HFD4225

Note

① UL listed for SWD applications, see NEC Article 240.83(d).

2.4

Molded Case Circuit Breakers

Series C

Type FDC Thermal-Magnetic Circuit Breakers with Non-Interchangeable Trip Units (Includes Terminals on Load End Only)

2

Maximum Continuous Ampere Rating at 40 °C	600 Vac Maximum, 250 Vdc 100 kAIC at 480 Vac		
	Two-Pole Catalog Number	Three-Pole Catalog Number	Four-Pole Catalog Number
15	FDC2015	FDC3015	FDC4015
20	FDC2020	FDC3020	FDC4020
25	FDC2025	FDC3025	FDC4025
30	FDC2030	FDC3030	FDC4030
35	FDC2035	FDC3035	FDC4035
40	FDC2040	FDC3040	FDC4040
45	FDC2045	FDC3045	FDC4045
50	FDC2050	FDC3050	FDC4050
60	FDC2060	FDC3060	FDC4060
70	FDC2070	FDC3070	FDC4070
80	FDC2080	FDC3080	FDC4080
90	FDC2090	FDC3090	FDC4090
100	FDC2100	FDC3100	FDC4100
110	FDC2110	FDC3110	FDC4110
125	FDC2125	FDC3125	FDC4125
150	FDC215	FDC3150	FDC4150
175	FDC2175	FDC3175	FDC4175
200	FDC2200	FDC3200	FDC4200
225	FDC2225	FDC3225	FDC4225

Types FDE, HFDE and FDCE 310+ Electronic Circuit Breakers with Non-Interchangeable Trip UnitsSee 310+ adjustability specifications on **Page V4-T2-289**.

Maximum Ampere Rating	Digitrip RMS 310+ Trip Unit Only		LSG Adjustable Short Time Pickup with I ² t Short Delay and Ground Fault Protection	LSIG Independently Adjustable Short Time Pickup and Ground Fault Protection	Neutral CT for LSG and LSIG Catalog Number
	Standard LS Adjustable Short Time Pickup with I ² t Short Delay Ramp Catalog Number	Optional LSI Independently Adjustable Short Time Pickup and Delay			
35 kAIC at 480 Vac / 18 kAIC at 600 Vac					
80	FDE308033	FDE308032	FDE308035	FDE308036	CTF080
160	FDE316033	FDE316032	FDE316035	FDE316036	CTF160
225	FDE322533	FDE322532	FDE322535	FDE322536	CTF225
65 kAIC at 480 Vac / 25 kAIC at 600 Vac					
80	HFDE308033	HFDE308032	HFDE308035	HFDE308036	CTF080
160	HFDE316033	HFDE316032	HFDE316035	HFDE316036	CTF160
225	HFDE322533	HFDE322532	HFDE322535	HFDE322536	CTF225
100 kAIC at 480 Vac / 25 kAIC at 600 Vac					
80	FDCE308033	FDCE308032	FDCE308035	FDCE308036	CTF080
160	FDCE316033	FDCE316032	FDCE316035	FDCE316036	CTF160
225	FDCE322533	FDCE322532	FDCE322535	FDCE322536	CTF225

Types FDE, HFDE, and FDCE 210+ Electronic Circuit Breakers with Non-Interchangeable Trip Units

Maximum Ampere Rating	Digitrip RMS 210+ Trip Unit Only	
	Standard LI Adjustable Instantaneous Catalog Number	Optional LSI Adjustable Short Time Pickup and Delay Catalog Number
35 kAIC at 480 Vac / 18 kAIC at 600 Vac		
100	FDE310021	FDE310022
150	FDE315021	①
225	FDE322521	FDE322522
65 kAIC at 480 Vac / 25 kAIC at 600 Vac		
100	HFDE310021	HFDE310022
150	HFDE315021	①
225	HFDE322521	HFDE322522

210+ Trip Electronic Trip Units Amperage Settings

Circuit Breaker Type	Frame	Ratings
FDE, HFDE	225	100, 110, 125, 150, 175, 200, 225
FDE, HFDE	150	70, 80, 90, 100, 110, 125, 150
FDE, HFDE	100	40, 50, 60, 70, 80, 90, 100

FDE 310+ Electronic Breaker with Zone Selective Interlocking

Ampere Rating	LSI w/ZSI Catalog Number	LSIG w/ZSI Catalog Number
35 kAIC at 480 Vac / 18 kAIC at 600 Vac		
80	FDE308032ZG	FDE308036ZG
160	FDE316032ZG	FDE316036ZG
225	FDE322532ZG	FDE322536ZG
65 kAIC at 480 Vac / 25 kAIC at 600 Vac		
80	HFDE308032ZG	HFDE308036ZG
160	HFDE316032ZG	HFDE316036ZG
225	HFDE322532ZG	HFDE322536ZG
100 kAIC at 480 Vac / 25 kAIC at 600 Vac		
80	FDCE308032ZG	FDCE308036ZG
160	FDCE316032ZG	FDCE316036ZG
225	FDCE322532ZG	FDCE322536ZG

Digitrip 310+ Electronic Trip Units Amperage Settings

Circuit Breaker Type	Frame	Ratings
FDE, HFDE, FDCE	225	100, 110, 125, 150, 160, 175, 200, 225
FDE, HFDE, FDCE	160	60, 70, 80, 90, 100, 125, 150, 160
FDE, HFDE, FDCE	80	15, 20, 30, 40, 50, 60, 70, 80

Note

① For 210+ trip unit, 150 A not available with LSI trip unit; entire range is covered by 100 A and 225 A frames.

Molded Case Switches

Eaton's molded case switches are used as compact switches in applications requiring high current switching capabilities. Molded case switches are constructed of circuit breaker

components and are of the high instantaneous automatic type. Molded case switches are listed in accordance with Underwriters Laboratories Standard UL 489.

Molded Case Switches

Maximum Continuous Ampere Rating at 40 °C	Complete Circuit Breaker with Load Side Terminals Only		
	480 Vac Maximum, 250 Vdc Catalog Number	600 Vac Maximum, 250 Vdc Catalog Number	
Two-Pole			
100	EHD2100K	FD2100K	HFD2100K
150	—	FD2150K	HFD2150K
225	—	FD2225K	HFD2225K
Three-Pole			
100	EHD3100K	FD3100K	HFD3100K
150	—	FD3150K	HFD3150K
225	—	FD3225K	HFD3225K
Four-Pole			
100	—	FD4100K	HFD4100K
150	—	FD4150K	HFD4150K
225	—	FD4225K	HFD4225K

Note

Molded case switches will open above 1800 amperes.

Accessories Selection Guide and Ordering Information

Line and Load Terminals

Line and load terminals provide wire connecting capabilities for specific ranges of continuous current ratings and wire types. Except as noted, terminals comply with Underwriters Laboratories Standards UL 486A and UL 486B. Unless otherwise specified, F-Frame circuit breakers are factory equipped with load terminals only.

Ordering Information

F-Frame circuit breakers and molded case switches have load terminals only as standard equipment. When standard line-end terminals (same as standard load-end terminals) are required, add Suffix **L** to the circuit breaker catalog number. When non-standard or optional line and/or load terminals are required, order by style number. Specify if factory installation is required.

Line and Load Terminals

Maximum Breaker Amperes	Terminal Body Material	Wire Type	AWG Wire Range	Metric Wire Range mm ²	Package of Three Terminals Catalog Number
Standard Pressure Type Terminals					
20 (EHD)	Steel	Cu/Al	14–10	2.5–4	3T20FB ①
100	Steel	Cu/Al	14–1/0	2.5–50	3T100FB
225	Aluminum	Cu/Al	4–4/0	25–95	3TA225FD
Optional Pressure Terminals					
50	Aluminum	Cu/Al	14–4	2.5–25	3TA50FB ①
100	Aluminum	Cu/Al	14–1/0	2.5–50	3TA100FD
200	Stainless steel	Cu	4–4/0	25–95	3T150FB
225	Copper	Cu	4–4/0	25–95	3T225FD
225	Aluminum	Cu/Al	6–300 kcmil	16–150	3TA225FDK3 ②
225	Aluminum	Cu/Al	6–300 kcmil	16–150	3TA225FDK ②③

Notes

- ① Not for use with ED, EDH, EDC breakers.
- ② Includes terminal shield kit. Adds approximately 3 inches (76.2) to breaker height. Available for use on three-pole breaker only.
- ③ Replacement use only.

2.4

Molded Case Circuit Breakers

Series C

Line and Load Terminals

2

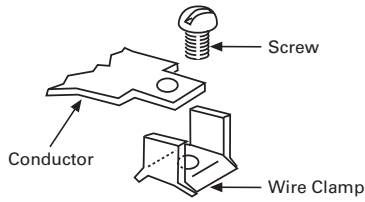

3T20FB

Assemble wire clamp to bottom of conductor as shown.

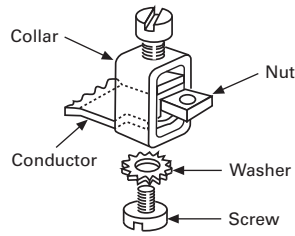

3T100FB, 3T150FB

Insert collar enclosing conductor as shown. Locate nut on top of conductor and tighten securely with screw and washer.

Caution: Collar must surround conductor.

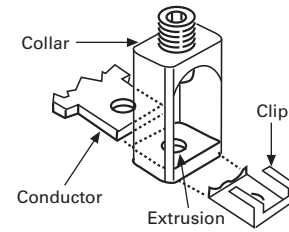

3TA225FD

Insert collar enclosing conductor and center on extrusion on collar. Install clip with legs on top of conductor and snap end around bottom of collar.

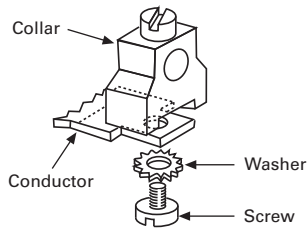

3TA50FB

Assemble collar on top of conductor as shown. Tighten securely with screw and washer.

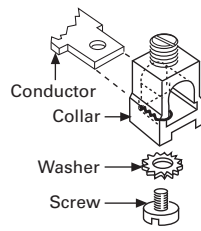

3TA100FD

Collar slides onto conductor and is held in position by a screw and lockwasher.

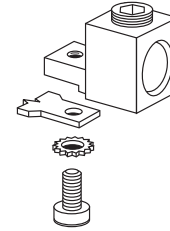

3TA225FDK3 (Up to 150 mm²)

Assemble collar on top of conductor as shown. Tighten securely with screw and washer. Terminal shield must be used with this collar.

Note: For 185 mm², use 3TA225FDK1. Same illustration for 3TA225FDK

Accessories

Different combinations of accessories can be supplied, depending on the types of accessories and the number of poles in the circuit breaker.

Allowable Accessory Combinations

FD Frame Accessories

Description	Reference Page	Single-Pole		Two-Pole		Three-Pole ①			Four-Pole			Neutral
		Center	Left	Right	Left	Right	Left	Center	Right	Left	Center	
Internal Accessories (Only one internal accessory per pole)												
Alarm lockout switch (make only)	V4-T2-413	■	—	—	—	—	—	—	—	—	—	—
Alarm lockout (Make/Break)	V4-T2-413	—	—	■	□	—	□	■	—	—	—	—
Alarm lockout (2Make/2Break)	V4-T2-413	—	—	■	□	—	□	■	—	—	—	—
Auxiliary switch (1A, 1B)	V4-T2-415	—	—	■	■	—	■	■	—	—	—	■
Auxiliary switch (2A, 2B)	V4-T2-415	—	—	■	■	—	■	■	—	—	—	■
Auxiliary switch and alarm switch combination	V4-T2-417	—	—	■	□	—	□	■	—	—	—	—
Shunt trip—standard	V4-T2-419	—	—	■	■	—	■	■	—	—	—	■
Shunt trip—low energy	V4-T2-423	—	—	■	■	—	■	■	—	—	—	—
Undervoltage release mechanism	V4-T2-425	—	—	■	■	—	■	■	—	—	—	—
External Accessories												
End cap kit	V4-T2-448	—	●	●	●	●	●	●	●	●	●	●
Keeper nut	V4-T2-448	●	●	●	●	●	●	●	●	●	●	●
Control wire terminal kit	V4-T2-449	●	●	●	●	●	●	●	●	●	●	●
Multiwire connectors	V4-T2-450	●	●	●	●	●	●	●	●	●	●	●
Rear fed terminals	V4-T2-450	●	●	●	●	●	●	●	●	●	●	●
Base mounting hardware	V4-T2-450	●	●	●	●	●	●	●	●	●	●	●
Terminal shields	V4-T2-452	●	●	●	●	●	●	●	●	●	●	●
Terminal end covers	V4-T2-453	—	—	—	●	●	●	—	—	—	—	—
Interphase barriers	V4-T2-453	—	●	●	●	●	●	●	●	●	●	●
Non-padlockable handle block	V4-T2-454	■	■	—	—	■	—	—	■	—	—	—
Snap-on padlockable handle lock hasp	V4-T2-454	■	■	—	—	■	—	—	■	—	—	—
Padlockable handle lock hasp	V4-T2-455	—	—	■	□	—	□	□	—	□	—	—
Cylinder lock	V4-T2-455	—	—	—	■	—	—	—	—	—	—	—
Key interlock kit	V4-T2-456	—	—	■	□	—	□	□	—	□	—	—
Sliding bar interlock—requires two breakers	V4-T2-457	—	—	—	●	●	●	—	—	—	—	—
Walking beam interlock—requires two breakers	V4-T2-457	—	—	—	●	●	●	●	●	●	●	●
Electrical (solenoid and motor) operators	V4-T2-458	—	—	—	●	●	●	●	●	●	●	●
Plug-in adapters	V4-T2-459	—	●	●	●	●	●	●	●	●	●	●
Rear connecting studs	V4-T2-461	●	●	●	●	●	●	●	●	●	●	●
Panelboard connecting straps	V4-T2-462	●	●	●	●	●	●	●	●	●	●	●
Handle mechanisms	V4-T2-539	—	—	—	●	●	●	—	—	—	—	—
LFD current limiter	V4-T2-464	—	—	—	●	●	●	—	—	—	—	—
IQ Energy Sentinel	V4-T2-464	—	●	●	●	●	●	—	—	—	—	—
Cause of trip display	V4-T2-465	—	—	—	●	—	—	●	—	—	—	—
Remote mount cause of trip display	V4-T2-465	—	—	—	●	—	—	●	—	—	—	—
Cause of trip LED	V4-T2-465	—	—	—	●	—	—	●	—	—	—	—
Modifications (Refer to Eaton)												
Special calibration	—	●	●	●	●	●	●	●	●	●	●	●
Moisture fungus treatment	V4-T2-254	●	●	●	●	●	●	●	●	●	●	●
Freeze-tested circuit breakers	—	●	●	●	●	●	●	●	●	●	●	●
Marine/naval application	—	●	●	●	●	●	●	●	●	●	●	●

Legend

- Applicable in indicated pole position
- May be mounted on left or right pole—not both
- Accessory available/modification available

Note

① Internal accessories are listed with Underwriters Laboratories (UL) for factory installation. They are not listed with UL for field installation.

Technical Data and Specifications

2

UL 489 Interrupting Capacity Ratings

Circuit Breaker Type	Number of Poles	Interrupting Capacity (kA Symmetrical Amperes)				Volts DC ^①	
		Volts AC (50/60 Hz)				125	250 ^{②③}
		240	277	480	600		
EDB	2, 3	22	—	—	—	10	—
EDS	2, 3	42	—	—	—	10	—
ED	2, 3	65	—	—	—	10	—
EDH	2, 3	100	—	—	—	10	—
EDC	2, 3	200	—	—	—	10	—
EHD	1	—	4	—	—	10	—
	2, 3	18	—	14	—	—	10
FDB	2, 3, 4	18	—	14	14	—	10
FD	1	—	35	—	—	10	—
	2, 3, 4	65	—	35	18	—	10
FDE ^④	3	65	—	35	18	—	—
HFD	1	—	65	—	—	10	—
	2, 3, 4	100	—	65	25	—	22
HFDE ^④	3	100	—	65	25	—	—
FDC ^⑤	2, 3, 4	200	—	100	35	—	22
FDCE ^{④⑤⑥}	3	200	—	100	25	—	—

IEC 157-1 (P1) Interrupting Capacity Ratings (P1)

Circuit Breaker Type	Number of Poles	Interrupting Capacity (kA Symmetrical Amperes)				Volts DC ^①	
		Volts AC (50/60 Hz)				125	250 ^{②③}
		220, 240	380, 415	440	500		
EDB	2, 3	22	—	—	—	10	—
EDS	2, 3	42	—	—	—	10	—
ED	2, 3	65	—	—	—	10	—
EDH	2, 3	100	—	—	—	10	—
EDC	2, 3	200	—	—	—	10	—
EHD	1	—	14	—	—	10	—
	2, 3	18	—	14	—	—	10
FDB	2, 3, 4	18	14	14	14	—	10
FD	1	35	—	—	—	10	—
	2, 3, 4	65	35	35	18	—	10
HFD	1	65	—	—	—	10	—
	2, 3, 4	100	65	65	25	—	22
FDC	2, 3, 4	200	100	100	35	—	22

210+ and 310+ Electronic Trip Unit Accessories

Description	210+	310+	Catalog number
Electronic portable test kit	■	■	MTST230V
Trip unit tamper protection wire seal	■	■	5108A03H01
External neutral sensor (80 A) ^⑦		■	CTF080
External neutral sensor (160 A) ^⑦		■	CTF160
External neutral sensor (225 A) ^⑦		■	CTF225
Compact external neutral sensor (80 A) ^⑦		■	CTFD080
Compact external neutral sensor (160 A) ^⑦		■	CTFD160
Compact external neutral sensor (225 A) ^⑦		■	CTFD225
Breaker-mount cause-of-trip indication		■	TRIP-LED
Breaker-mount ammeter module		■	DIGIVIEW
Remote-mount ammeter module		■	DIGIEWR06

UL 489 Current Limiting Data

Frame	Circuit	I _p (kA)	I ² T (10 ⁶ A ² S)
FDC	240 V/200 kA	41.4	1.41
FDC	480 V/100 kA	38.9	2.50
FDC	600 V/35 kA	29.0	3.00

Notes

- ① DC ratings apply to substantially non-inductive circuits.
- ② Two-pole circuit breaker, or two poles of three-pole circuit breaker.
- ③ Time constant is 3 milliseconds minimum at 10 kA and 8 milliseconds minimum at 22 kA.
- ④ Electronics available on three-pole only, no DC rating for FDE, HFDE, FDCE.
- ⑤ Current limiting.
- ⑥ Check with Eaton for availability.
- ⑦ Neutral sensor required for four-wire systems if neutral protection is desired; sold separately.

FDE 210+ and 310+ Specifications

Description	Digitrip RMS 210+	Digitrip RMS 310+
Breaker type		
Frame designation	FD	FD
Frames available	100 A, 150 A, 225 A	80 A, 160 A, 225 A
Continuous current range (A)	40–225 A	15–225 A
Ground fault pickup (A)	N/A	16–225 A
Interrupting capacities at 480 Vac (kAIC)	35, 65, 100	35, 65, 100
Protection		
Ordering options	LI, LSI	LS, LSI, LSG, LSIG
Arcflash Reduction Maintenance System™ (or Maintenance Mode)	No	No
Interchangeable trip unit	No	No
High load alarm (suffix B20)	No	No
Ground fault alarm with trip (suffix B21)	No	No
Ground fault alarm, no trip (suffix B22)	No	No
Zone selective interlocking (suffix ZG)	No	LSI, LSIG
Cause of trip indication	No	Yes
Thru-cover accessories	No	No
Test kit available	Yes	Yes

FDE 210+ Adjustability Specifications

210+ settings		FD Frame		
		100 A	150 A	225 A
I_r = continuous current or long delay pickup (amperes) (all 210+)	I_r			
	A	40	70	100
	B	50	80	110
	C	60	90	125
	D	70	100	150
	E	80	110	175
	F	90	125	200
	G (= I_n)	100	150	225
	I_i (x I_n) = Instantaneous pickup (210+ LI version)	I_i	100	150
J–2x		200	300	450
K–2.5x		250	375	565
L–3x		300	450	675
M–3.5x		350	525	790
N–4x		400	600	900
O–5x		500	750	1125
P–6x		600	900	1350
Q–8x		800	1200	1800
R–10x		1000	1500	2250
S–12x ①		1200	1800	2400
Fixed instantaneous override (all 210+)		2400	2400	2400
"Isd (x Ir) / tsd = SD profile" ② (210+ LSI version)	I_{sd} / t_{sd}	100	150	225
	J	2x / 150	N/A	2x / 150
	K	2x / 300	N/A	2x / 300
	L	2x / I^2t	N/A	2x / I^2t
	M	4x / Inst	N/A	4x / Inst
	N	4x / 150	N/A	4x / 150
	O	4x / I^2t	N/A	4x / I^2t
	P	6x / Inst	N/A	6x / Inst
	Q	6x / 300	N/A	6x / 300
	R	10x / 150	N/A	10x / 150
	S	10x / 300	N/A	10x / 300

FDE 310+ Adjustability Specifications

310+ Settings		FD Frame		
		80 A	160 A	225 A
I_r = continuous current or long delay pickup (amperes) (All 310+)	I_r			
	A	15	60	100
	B	20	70	110
	C	30	80	125
	D	40	90	150
	E	50	100	160
	F	60	125	175
	G	70	150	200
	H (= I_n)	80	160	225
t_r = long delay time (seconds) (All 310+)	Position 1	2	2	2
	Position 2	4	4	4
	Position 3	7	7	7
	Position 4	10	10	10
	Position 5	12	12	12
	Position 6	15	15	15
	Position 7	20	20	20
	Position 8	24	24	24
	I_{sd} (x I_r) = short delay pickup (All 310+)	Position 1	2x	2x
Position 2		3x	3x	3x
Position 3		4x	4x	4x
Position 4		5x	5x	5x
Position 5		6x	6x	6x
Position 6		7x	7x	7x
Position 7		8x	8x	8x
Position 8		10x	10x	10x
Position 9		12x	12x	12x
t_{sd} = short delay time I^2t (milliseconds) (LS, LSG)	Fixed	67 at10x	67 at10x	67 at10x
	Position 1	Inst	Inst	Inst
	Position 2	120	120	120
t_{sd} = short delay time flat (milliseconds) (LSI, LSIG)	Position 3	300	300	300
	Position 1	16	32	45
	Position 2	24	48	67
I_g = ground fault pickup (amperes) (LSG, LSIG)	Position 3	32	64	90
	Position 4	48	96	135
	Position 5	64	128	180
	Position 6	80	160	225
	Position 1	Inst	Inst	Inst
	Position 2	120	120	120
t_g = ground fault delay time (milliseconds) (LSG, LSIG)	Position 3	300	300	300
	Independently Adjustable Instantaneous (I_i) setting ①			
Maintenance Mode pickup ($2.5 \times I_n$) (amperes) ②				

Notes

- ① Not available for FD. Independently adjustable I_i setting available in LG, NG and RG ALSI and ALSIG trip units.
- ② Maintenance Mode not available for FD frames. It is available for KD, LD, MDL, LG, NG and RG.

2.4

Molded Case Circuit Breakers

Series C

Dimensions and Weights

Approximate Dimensions in Inches (mm)

2

FD Frame

Number of Poles	Width	Height	Depth
1	1.38 (35.1)	6.00 (152.4)	3.38 (86.0)
2	2.75 (70.0)	6.00 (152.4)	3.38 (86.0)
3	4.13 (105.0)	6.00 (152.4)	3.38 (86.0)
4	5.50 (139.7)	6.00 (152.4)	3.38 (86.0)

FD Frame, Three-Pole

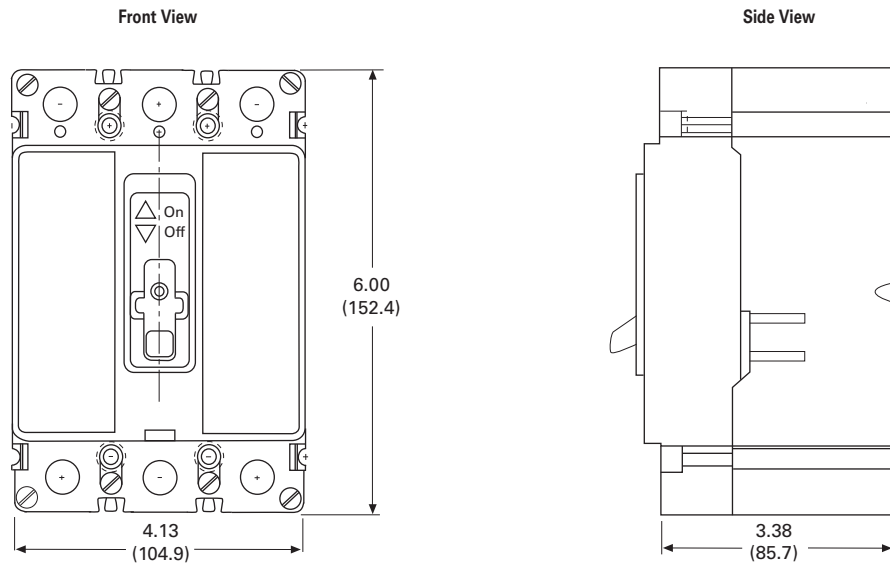

Approximate Shipping Weight Lbs (kg)

FD Frame

Breaker Type	Number of Poles			
	1	2	3	4
ED, EDB, EDS, EDH, EDC	—	3 (1.4)	4.5 (2.0)	—
EHD, FDB, FD, HFD, FDC	2 (0.9)	3 (1.4)	4.5 (2.0)	6 (2.7)
FDE, HFDE, FDCE	—	—	4.5 (2.0)	—